

LONDON WEST  
INNOVATION  
DISTRICT

# Catalysing a silicon valley for aviation and logistics

February 2021

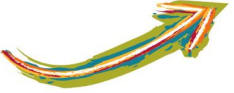

LONDON WEST  
INNOVATION  
DISTRICT

# Overview

- Journey to date
- Ambition
- Objectives – what's different?
- Emerging opportunity areas
- Learning from other places
- Next steps

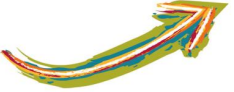

# Journey to date

- Innovation for Sustainable Airports, SIA, Brunel for BEIS, Summer 2018
- Sub-regional innovation district idea seeded in the WLA's Build & Recover Plan; but we already have a local district at White City and investment in pipeline for a Slough Innovation Space, for example
- Soft launched concept at Blue Skies Conference, Nov 2020 – over 250 participants and supports including Dnata, SAP, Heathrow, govt and academia
  - Delivered and supported on a cross party basis including the Aviation minister and Kwasi Kwarteng MP; keynotes from OECD and Singapore High Commissioner
- Local steering and advisory groups – currently co-chaired by Seema Malhotra MP Feltham & Heston and Andrew Dakers, CEO, WLB
- CRL accelerator, Hayes – UK's leading accelerator for hardware based start-ups – has agreed to be home of innovation district hub, with many spokes

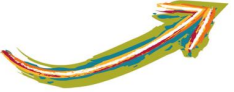

# Ambition

**“A new platform through which players can come together to collaborate and innovate for the future and secure larger scale opportunities for new investment, growth and jobs. As an aviation and logistics based innovation district, it is the first of its kind.**

“Over time, the new innovation district will become the Silicon Valley of aviation, networking people and places across the UK and internationally, nurturing new skills, new products and reshaping services.

“Collaborations will support innovations in materials, manufacturing, as well as hardware and software technologies, including AI, for national and global markets; driving growth through supply chains.”



It will pursue a quadruple or quintuple innovation helix approach...

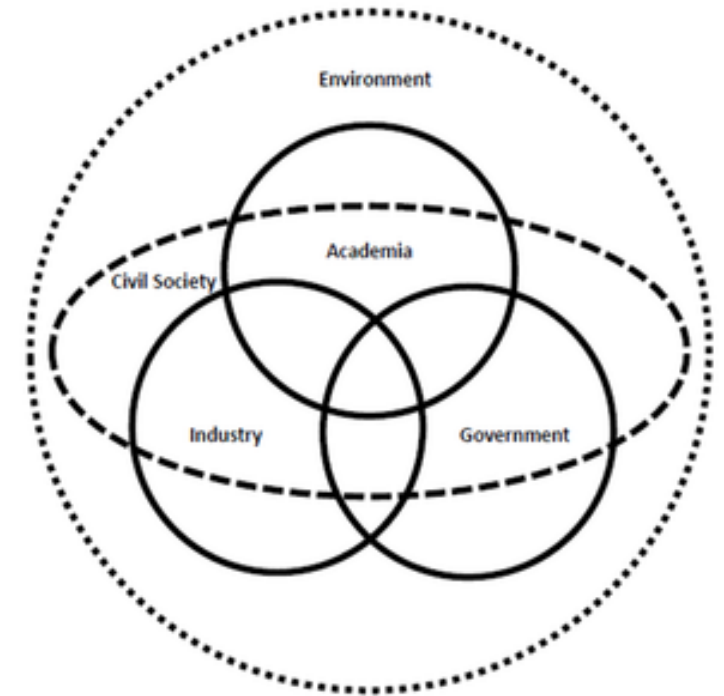
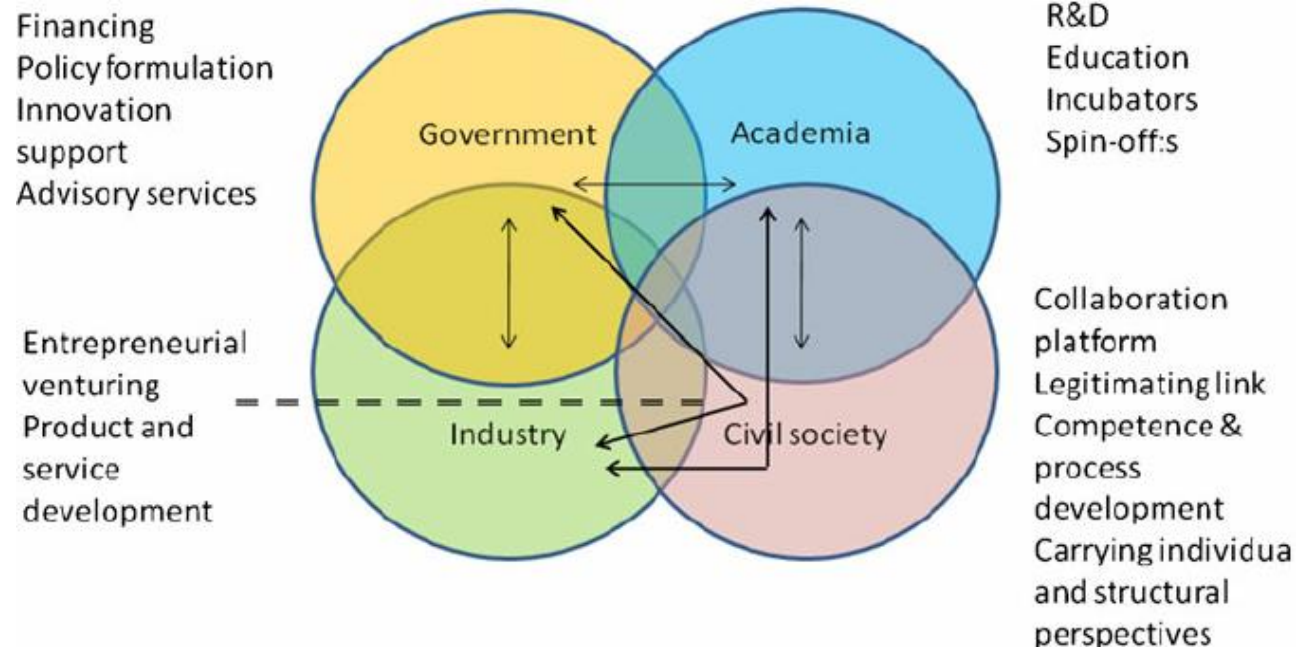





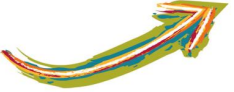

# What's different?

- A **'mega district'** that will create an environment where innovators and entrepreneurs develop and test new ideas in cross-sector partnerships close to problems/ opportunities relating to the future of green, circular economy aviation and logistics.
- Members of the Innovation District will **create a vision of the future of the Heathrow ecosystem/ economic area** together with a roadmap for realising that vision.
- **National and international connector**
- **Innovations will be piloted, developed and hopefully scaled, in one of the world's largest living laboratories.**
- **Strong links to education system** (schools, colleges and HE) to help alignment to future emerging needs through visibility of innovation pipeline.

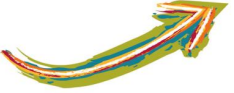

# Emerging opportunity areas

- Data and open data
- Digital logistics and cargo
- Jet Zero
- AI and ways of working for greater productivity
- Improved passenger experience
- Low carbon food
- Cyber security



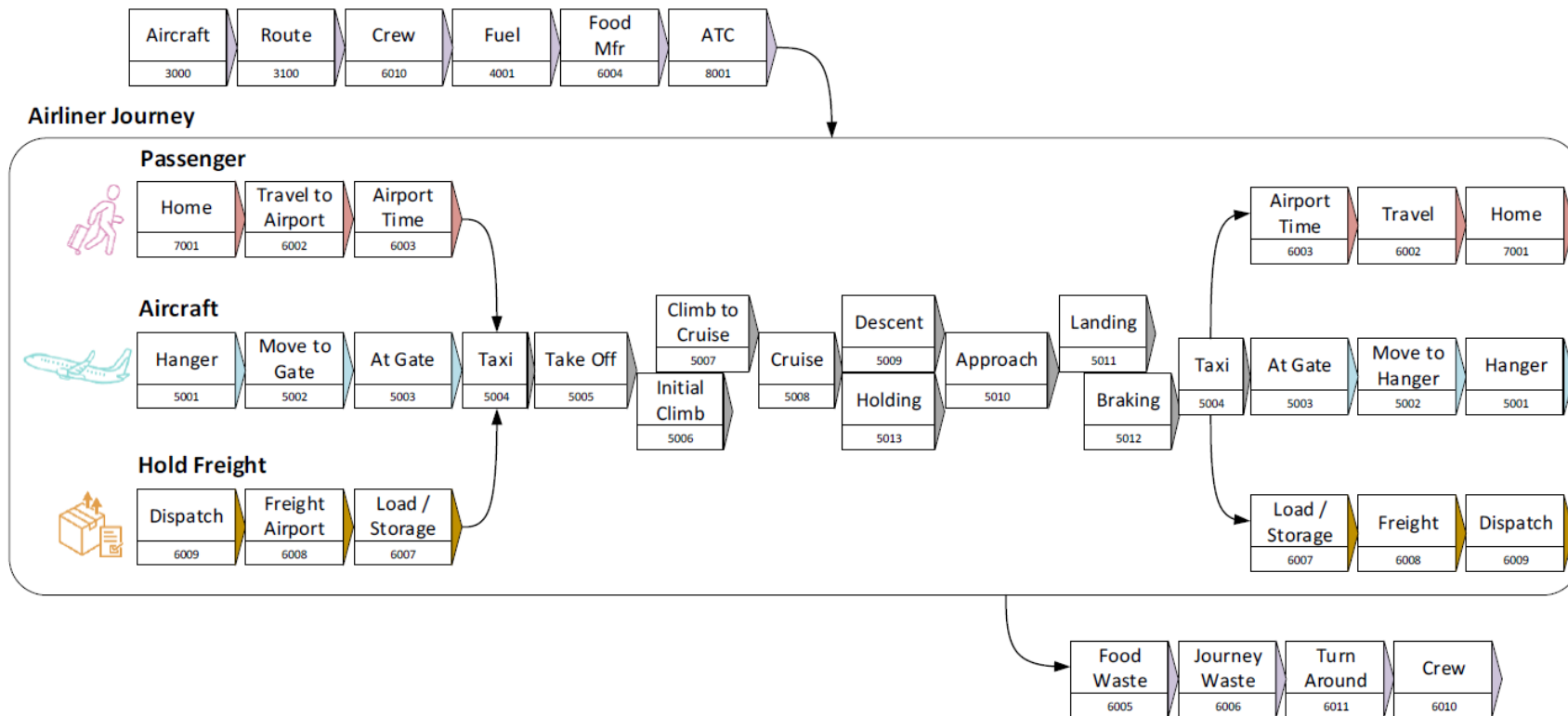
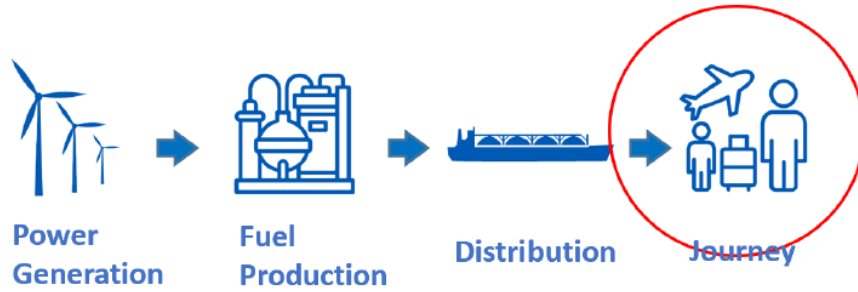

*Opportunity to find London West focus areas in Whittle Lab/ WEF/ McKinsey model for aviation's carbon footprint*

# Learning from other places

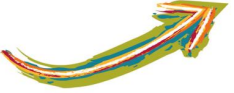

LONDON WEST  
INNOVATION  
DISTRICT



**Copenhagen Science City, Denmark**



**Oslo Science City, Norway**



**Porto Digital, Brazil**



**Tallinn Airport, Estonia**

*...and the UK Innovation Districts Group*

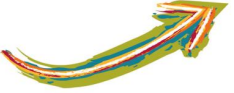

# Next steps

Three events Feb – June '21 to hone business plan:

- Feb - Briefing for City Hall officers with CBI / WLA reps
- Mid-March - Mini conference (40-50 people) invite only. Unpack London West contribution to zero carbon aviation drawing on Whittle Lab model and identifying practical opportunities.
- May/June - Skills and talent strategy roundtable; how do we ensure schools and colleges have line of sight into Innovation District's work?

Ongoing stakeholder engagement and input, including on:

- Governance
- Funding – project director/ coordinator first priority

Baseline research on innovation landscape: HE, patent filings, Innovate UK funding...



LONDON WEST  
INNOVATION  
DISTRICT

# Appendices

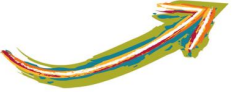

# Initial thoughts on Governance options – decision to be made in Q1/2 2021

- **Option 1**: Initially constitute as an unincorporated association. Need to be clear with all partners that IP is vested in the association from outset; CRL funded to employ one member of staff to service WLID development and WLB to run conference. After year one, or as funding available, we incorporate.
- *Advantages: Avoids initial admin burden, need to set up bank account during COVID etc. Allows governance model to be tested/ evolved and for this to inform design of incorporated legal entity. Leverages partners infrastructure. Partner(s) could hold fund on behalf of association.*
- *Disadvantages: Needs carefully management of org's IP (e.g. brand collateral) to avoid any later disputes between founding partners – and asset transfer of IP etc when incorporated.*
- **Option 2**: Constitute as a CIC, CIO or company limited by guarantee and try to set-up bank account immediately. Could then potentially employ staff member directly. Would still look to CRL for space/ process design etc and WLB for major events support.